

# Stratocaster Humbucking Switch

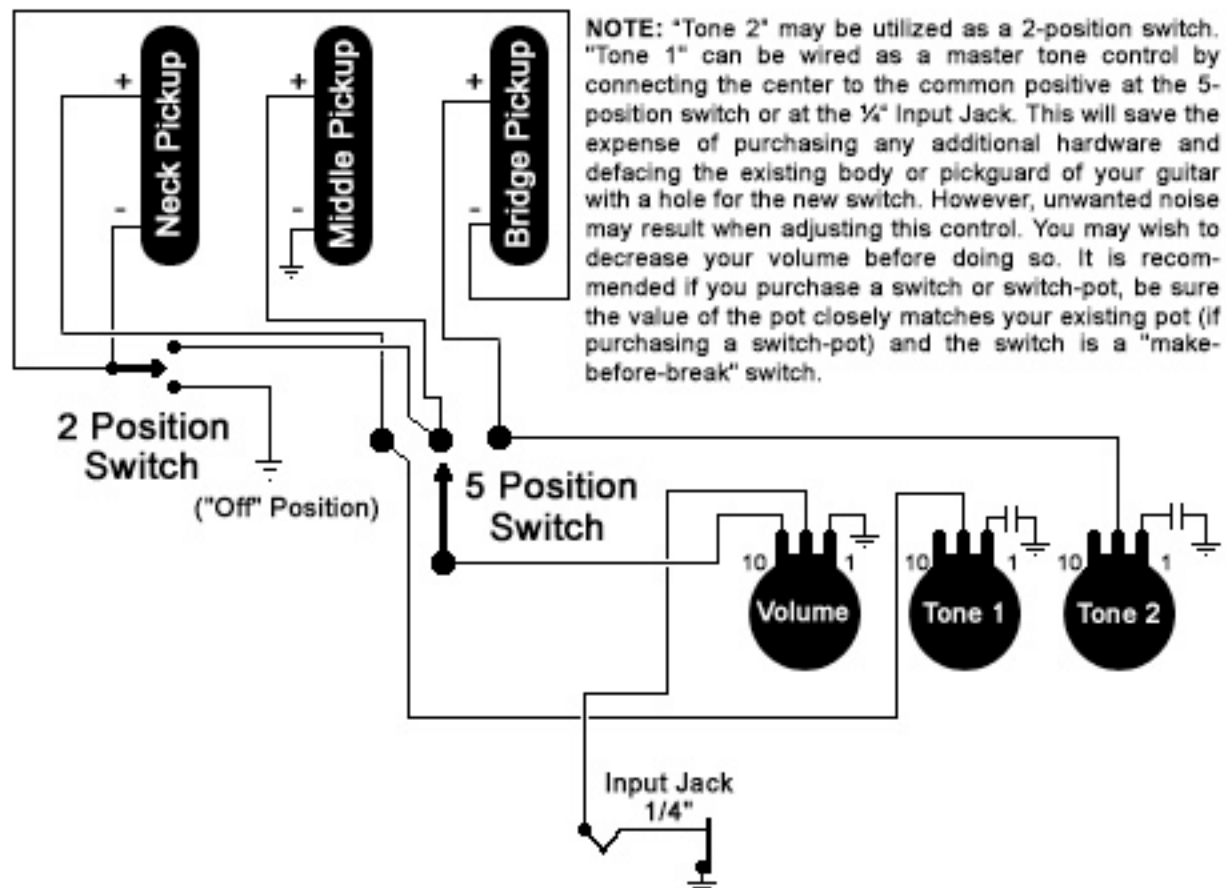

By utilizing a switch, push-pull pot switch, or one of the tone control pots, you can acquire the "crunch" of a humbucking double-coil pickup while still achieving the slightly out-of-phase tone of the Stratocaster single-coil pickups. In the second and fourth positions of the Stratocaster 5-position switch, you have two pickups wired in **parallel**. By using the 2-position switch in the diagram above with the Stratocaster switch in the first or fifth position, you have two pickups wired in **series**, increasing the impedance and thus the output to the amplifier. You will notice a warmer tone and increased sustain. This will give the strat user an excellent alternative for distortion sounds without the expense of purchasing new pickups.